



MATERIAL HANDLING REDEFINED.

RICO

CAPACITIES RANGING FROM
15,000 TO 100,000 LBS.



RICO



INNOVATIVE SOLUTIONS FOR MATERIAL HANDLING

OUR REPUTATION AS A PIONEER IN

Design & Development

RICO is a leading manufacturer of engineered material handling equipment. Our 130 years of expertise in this industry has resulted in RICO'S reputation as a pioneer in the design, development, and creation of equipment with capacities from 3000 to over 300,000 pounds.

With our headquarters located in Medina, Ohio, our major client base is involved in industrial, commercial, automotive and military markets and our products are used around the globe.

We are very proud to be one of the most self-sufficient companies in this industry. With over 98 % of our work performed in-house from design to fabrication to assembly, we are truly unique in the material handling equipment manufacturing arena.

That means you get:

Quicker Delivery,

Flexible Production Schedules,

Rapid Prototyping,

High Standards for Quality,

Increased Equipment Reliability,

The HIGHEST Level of Tech Support.

That is the **RICO ADVANTAGE.**

FLEXIBILITY. VERSATILITY. EFFICIENCY.

Outstanding Performance

Pegasus, the newest creation from RICO, screams INNOVATIVE SOLUTION, which has become a trademark of RICO since the company began operation.

Using our engineering and design expertise we have gained over the years developing material handling equipment, PEGASUS has been created as a mill-duty truck in 3 versions: electric, LP Gas or Diesel.

PEGASUS has been ergonomically designed for operators and service technicians alike, making life just that much easier. With a cab forward design providing comfort and convenience, the PEGASUS is truly one of a kind.

- Healthy Posture accomplished through semi-suspension or an air ride seat.
- Seat back angle, weight and adjustments are at your fingertips.
- An integrated seat switch, a "kill" switch allows for safe operation ONLY while seated.
- Tilt steering allows for comfortable operation regardless of operator's height.
- Integral side-shifting fork positioner.

Safety is critical as we included large steps, easy to reach rails, and exits from both sides of the PEGASUS. Visibility has been maximized to improve operation by utilizing our cab forward and higher operator seat design.



Flexibility. Versatility. Efficiency. All trademarks of Rico and all incorporated into the PEGASUS. From various lift heights, capacities and options to handle a diverse list of applications, it has been built in true Rico style.

SUPERIOR PERFORMANCE & RELIABILITY.

PEGASUS is designed for the most rigorous application... Mill-Duty. Through the use of thermostat controlled hydraulic oil coolers and a heavy duty caster steer, coupled with the heaviest chassis ever experienced in the market, PEGASUS is truly unique.

In our design of the PEGASUS, we took more into account than just motion. We developed our drive axle to provide long life and marginal downtime. Our design includes a 14 inch diameter oil-emersed hydraulically actuated wet disk brakes for capacities up to 40,000 pounds. This design allows for brake performance and a longevity never before seen in this industry.

We use A36 plate and high strength structural steel on all welded frames of the PEGASUS. Strong, pre-heated, multiple-pass frame welds specifically designed for the most severe operating conditions are a trademark of the Rico Product family.

The mast design incorporates a wide, upright spread to allow for easy, accurate load spotting. We maximized the strength of the masts by utilizing rolled or machined forgings instead of welded uprights that have been know to fail.



INNOVATIVE SOLUTIONS FOR MATERIAL HANDLING

SIMPLE MAINTENANCE.

An incredible amount of effort was put into designing the PEGASUS family of trucks with high access to maintenance needs to prolong the life of the equipment.

- *A central lubrication system.*
- *Conveniently located electrical panel for test point and control fuses.*
- *Sealed hydraulic wet disc brake system.*
- *Roll out hydraulic motor.*

We included a large electrical compartment to make maintenance simple and accessible. A removable cab design allows for easy access to all major components.

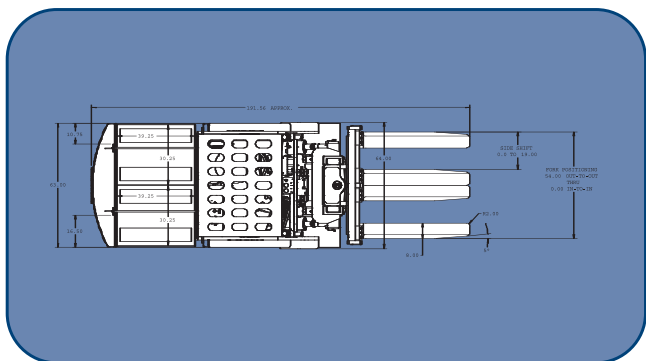

PEGASUS is a true innovative solution from RICO.

The type of real solution to the real problems you face as a company.

The type of solution you have come to expect from RICO.

For more information about PEGASUS or any of the other solutions we provide, please contact us at: 330-723-4050.

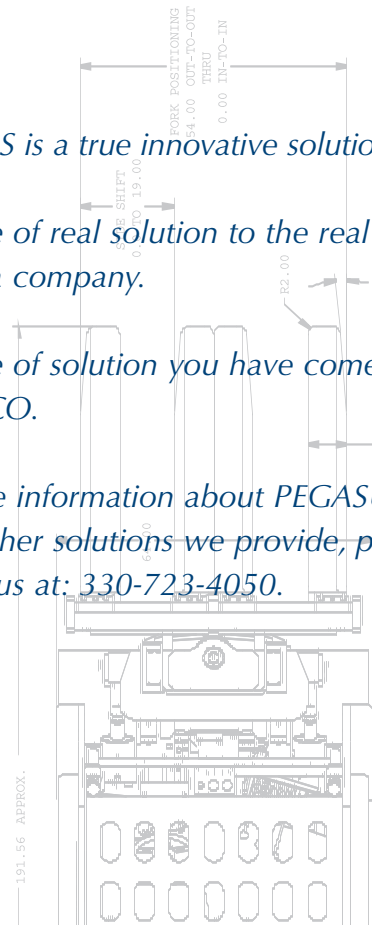
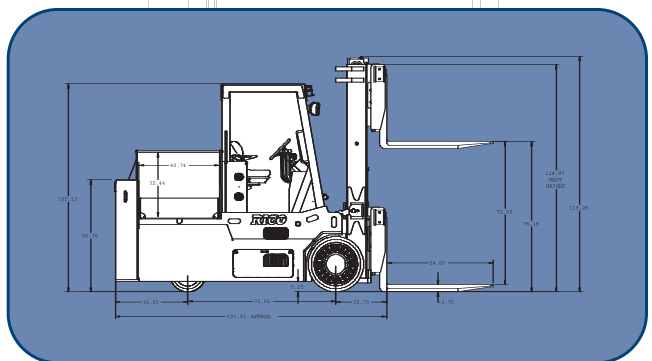

SUPERIOR INNOVATIONS
Engineering &



HEALTHY POSTURE

- Specifically designed for forklifts, the seat compensates for vibrations
- Seat back angle, weight, and fore / aft adjustment are all just a click away.
- Integrated seat switch ensures safety by only allowing travel of the vehicle while seated.



MAST & FORKS

- Wide upright spread allows the operator to see straight through the mast for easy, accurate load spotting
- Solid forged forks for maximum strength
- Proportioned taper on forks for coil handling applications
- Integral side-shifting fork positioner



DRIVE AXLE

- Heavy duty planetary drive axle with integral wet disc brakes.

Design



CAB DESIGN

- Maximum visibility.
- Removable cab designed to access all major components.



STEER WHEELS

- Heavy duty caster steer for truck capacities of 25,000 lbs. or more.
- Heavy duty knuckle steer for truck capacities of 15,000 and 20,000 lbs. or more.

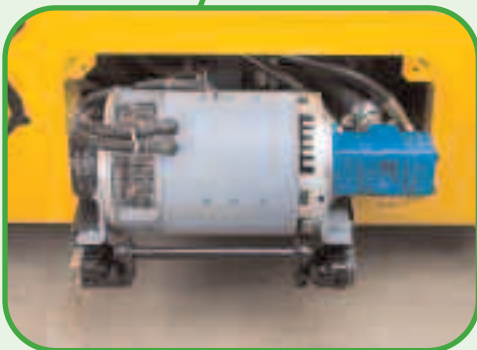

ACCESSIBILITY

- Maintenance friendly, easy access, roll-out hydraulic motor.



RICO

BPR/RICO Equipment, Inc.
120 North State Rd.
Medina, OH 44256

p: 330.723.4050
f: 330.723.4012

www.RicoEquipment.com